



Instructions for the Assembly of Scotchflex Printed Circuit Board Connectors

General:

Scotchflex printed circuit board connectors can be terminated before or after being soldered. Scotchflex locator plates 3443-15, 3443-16, 3443-19, 3443-33 and 3443-34 are drilled to relieve the solder contacts **before** being soldered. Locator plate 3443-8 has a rubber cushion to relieve the solder contacts and fillets **after** being soldered. These locator plates are used with Scotchflex manual or pneumatic assembly presses and other convenient assembly tooling to reduce set-up time, to provide easier and faster assembly, and to reduce assembly error.

Scotchflex printed circuit board connectors are designed for production wave soldering, but hand soldering is acceptable. Avoid excessive or prolonged temperature. Connectors should be held down to prevent "floating" during wave soldering. When hand soldering, apply the soldering iron to the printed circuit pad, and bridge the solder around and onto the contact.

Number of Contacts	Product Part No.	3M Locator Plate No.	Shut Height Setting		Platen Part No.
			3440, 3440A, 3640 Press	3335, 3335-1 3339, 3339-1	
10	3474-0000	3443-15	2	2½	3442-1A
		†3443-8	3*	3½*	
	3474-0000T	3443-15	2	2½	
		†3443-8	3*	3½*	
	3474-0001T	3443-15	2	2½	
		†3443-8	4**	4½**	
20	3422-0000	3443-16	2	2½	3442-1A
		†3443-8	3*	3½*	
	3422-0000T	3443-16	2	2½	
		†3443-8	3*	3½*	
	3422-0001T	3443-16	2	2½	
		†3443-8	4**	4½**	
24	3470-0000T	3443-34	3	3½	3442-1A
		†3443-8	4*	4½*	
26	3434-0000	3443-15	2	2½	3442-1A
		†3443-8	3*	3½*	
	3434-0000T	3443-15	2	2½	
		†3443-8	3*	3½*	
	3434-0001T	3443-15	2	2½	
		†3443-8	4**	4½**	
28	3468-0000T	3443-33	3	3½	3442-1A
		†3443-8	4*	4½*	
34	3402-0000	3443-15	2	2½	3442-1A
		†3443-8	3*	3½*	
	3402-0000T	3443-15	2	2½	
		†3443-8	3*	3½*	
	3402-0001T	3443-15	2	2½	
		†3443-8	4**	4½**	
36	3378-0000T	3443-19	4	4½	3442-2
		†3443-8	4*	4½*	
40	3418-0000	3443-16	2	2½	3442-1A
		†3443-8	3*	3½*	
	3418-0000T	3443-16	2	2½	
		†3443-8	3*	3½*	
	3418-0001T	3443-16	2	2½	
		†3443-8	4**	4½**	
50	3426-0000	3443-15	2	2½	3442-1A
		†3443-8	3*	3½*	
	3426-0000T	3443-15	2	2½	
		†3443-8	3*	3½*	
	3426-0001T	3443-15	2	2½	
		†3443-8	4**	4½**	

*Connector soldered to .062" board
 **Connector soldered to .125" board

†For assembly **after** soldering, use plate 3443-8.

Assembly:

1. Remove platen from assembly press and adjust the press shut height to the appropriate gauge setting. (Figure 1)
2. Position the locator plate on the assembly press table over the mounting studs for right, left or front cable entry.
3. Replace platen and position parallel with the connector length.

4. Unsoldered Connector:

Locate a connector body on the locator plate so the solder contacts are within the relief holes.

Soldered Connector:

Locate a connector body to a PC board over the rubber cushion.

The connector body should be centered directly below the assembly press shaft.

5. Remove a connector cover from the paper liner by snapping cover down against adjacent cover, and then pulling laterally away from liner. (Figure 2)
6. Press ribbed side of cable into cover alignment grooves. Visually inspect to insure that:
 - a. Cable is properly aligned in connector cover grooves.
 - b. Cable end is flush with cover for end terminations or perpendicular to cover for bussing.
7. Place the connector cover and cable over the connector body, aligning the cover holes with the cover retaining posts. Push down firmly.
8. Complete the connection by lowering the assembly press handle fully.
9. Visually inspect to insure that: (Figure 3)
 - a. Cover is fully seated and parallel with body.
 - b. Cover is properly aligned with cable.
 - c. Connector is parallel with PC board.

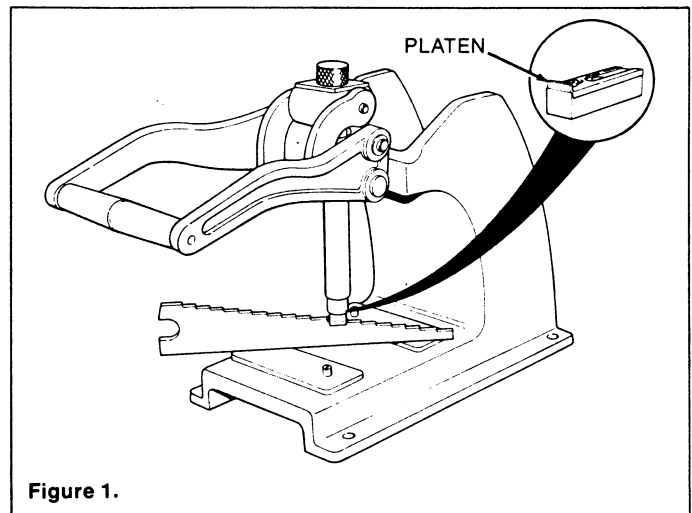

Figure 1.

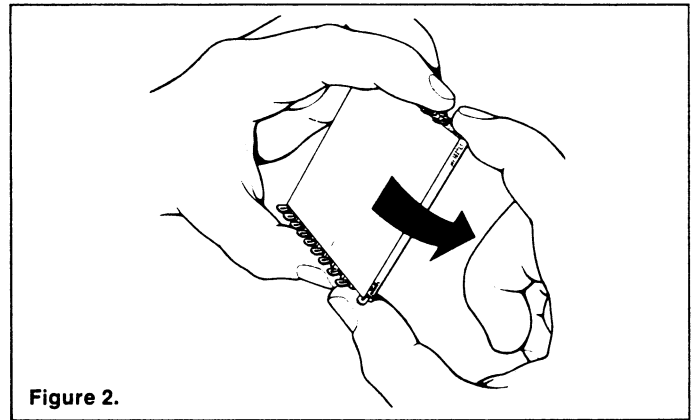

Figure 2.

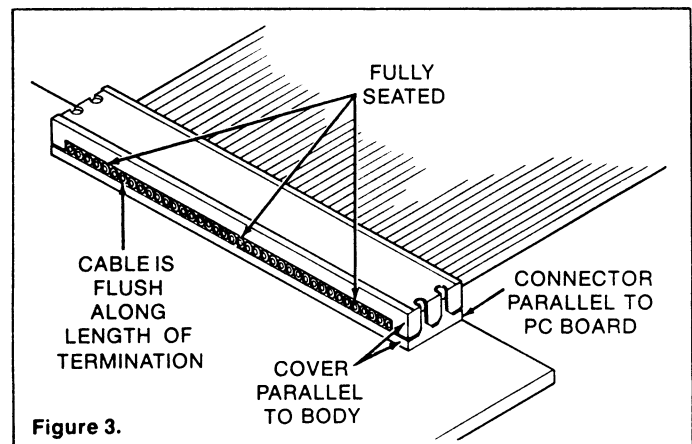

Figure 3.

Important Notice to Purchaser:

All statements, technical information and recommendations contained herein are based on tests we believe to be reliable, but the accuracy or completeness thereof is not guaranteed, and the following is made in lieu of all warranties expressed or implied:

Seller's and manufacturer's only obligation shall be to replace such quantity of the product proved to be defective. Neither seller nor manufacturer shall be liable for any injury, loss or damage, direct or consequential, arising out of the use of or the inability to use the product. Before using, user shall determine the suitability of the product for his intended use, and user assumes all risk and liability whatsoever in connection therewith.

No statement or recommendation not contained herein shall have any force or effect unless in an agreement signed by officers of seller and manufacturer.